

# Use for Now, Save for Later

## Finally, Resealable Flex Duct!

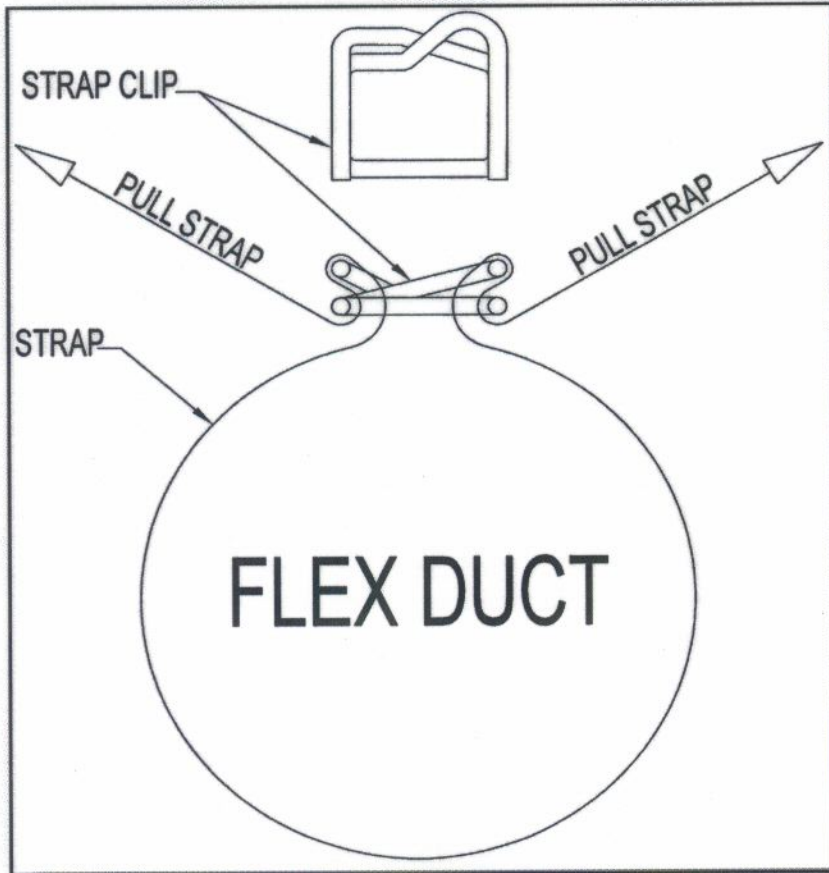

Now, with Gray Flex's NEW Metering Device (Patent # 7,681,729) you don't have to waste the rest of your time and unused flex duct anymore. A simple device that lets you secure compressed flex duct at the point of dissection, keeping the rest of the flex compressed for future use.

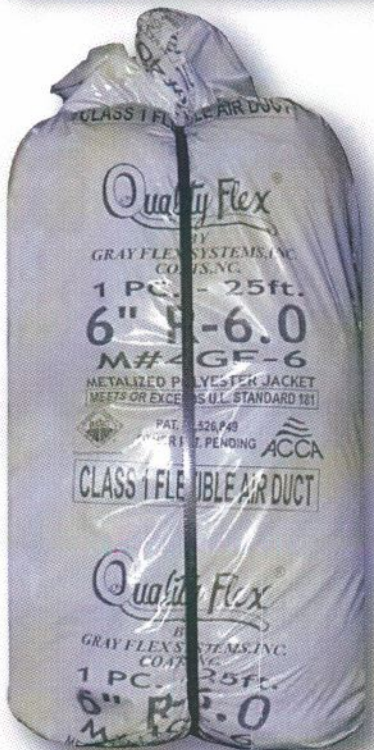

**SIMPLE**  
**PORTABLE**  
**CONVENIENT**  
**DURABLE**  
**REUSABLE**  
**ECONOMIC**

**Quality Flex<sup>®</sup>**

GRAY FLEX SYSTEMS, INC.

232 N. IDA ST.

COATS, NC. 27521

PH: 910-897-3539

FX: 910-897-2222

WWW.GRAYFLEX.COM



# Gray Flex Metering Device Instructions

Patent # 7,681,729



*First determine how much flex duct is required.*

**Fig.1**

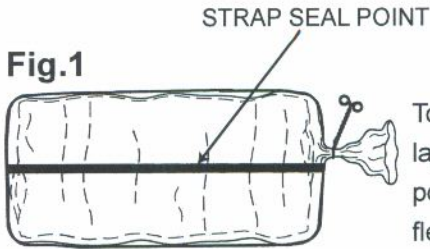

To remove straps, peel back top layer strap from heat sealed point. To determine the length of flex duct see Fig.3(A).

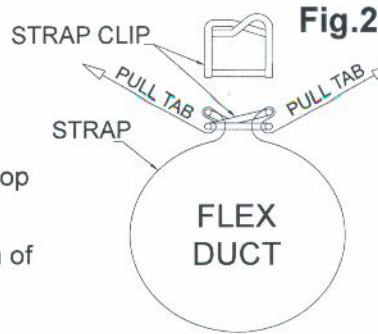
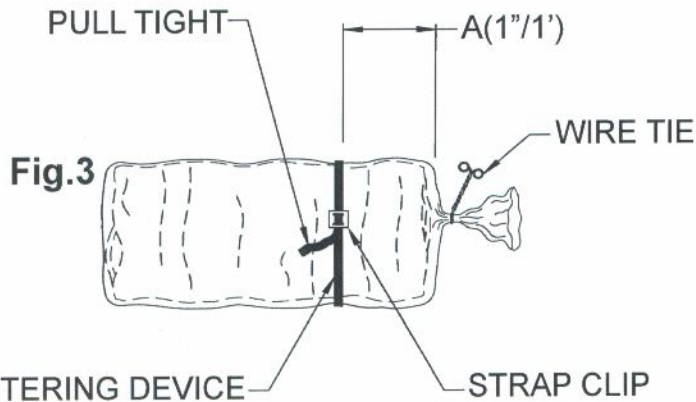

**Fig.2**

This diagram shows how the removed strap is threaded through the strap clip to insure a tight securement around the flex duct. Be sure to apply equal retractable pressure with both viable tabs to prevent strap slippage.

*Unbagged flex is 25ft.*

*A= 1in. of bagged flex is approx. 1ft. of unbagged flex.*



**Fig.3**

After strap is threaded evenly into strap clip, position strap flatly around the circumference of the flex after the desired length of needed flex is determined. Again(Fig.2), be sure to apply equal retractable pressure with both viable tabs to keep tight and prevent slippage. *Keep device secure until the unused portion of flex duct is resealed with wire tie.*

**Fig.4**

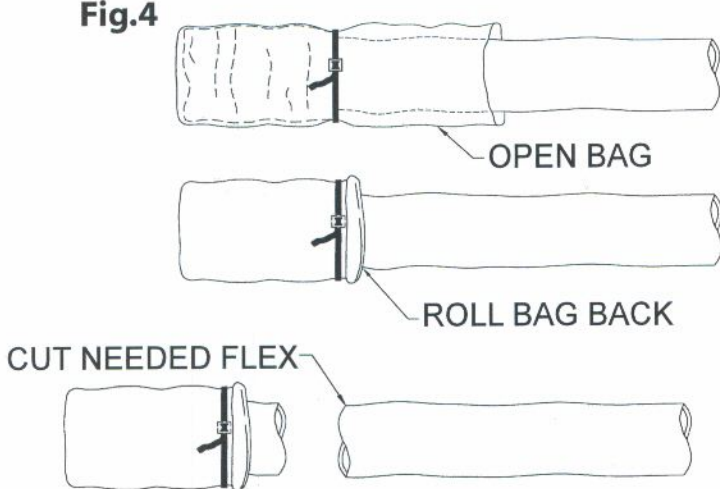

**Fig.5**

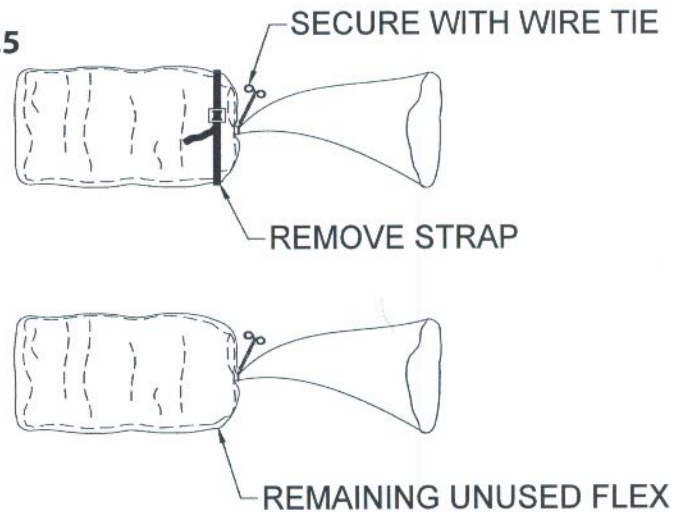

*\*Use wire cutters and pliers in completing this step(Fig.4)\**  
 Using pliers, untwist wire tie and remove from bag. Make sure to keep the tie for reapplication (see Fig.5.) Pull determined length of flex from bag (see Fig.4) and roll top portion of bag back to metering device. Cut flex at the prior determined location, using wire cutters to cut wire in core.

Push the remaining flex down to a point that gives you enough room so you can easily reseat the bag. Pull bag top portion back around the unused flex. Grab the bag and hold tight at this point, secure remaining bag with the wire tie from Fig.4 and twist with pliers to tighten. Finally release metering device, and your job is done.